

Imo Pump

Model 3E

1-100 GPM

Up to 150 PSI

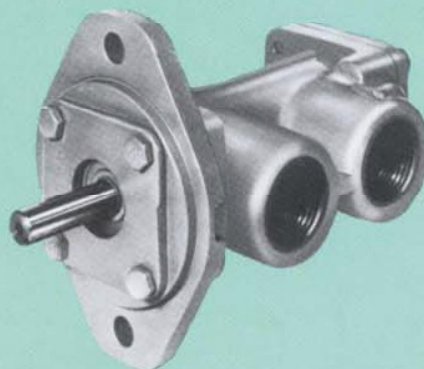

IMO Model 3E pumps are three screw, positive displacement, rotary pumps designed and engineered for excellent suction capability over a wide range of fluid viscosities. Flow rates (1 to 100 GPM) are proportional to rotating speed when the pump is operated within the recommended pressure range. The pump has the ability to self-prime in a piping system designed to facilitate this feature.

The unique IMO design—only three moving parts—is the key to the model 3E pump performance. A precision bored housing encases the driven screw (power rotor) and intermeshing sealing screws (idler rotors). The accurately machined idler rotors conform perfectly to the threads of the power rotor and to the housing bores confining the fluid in a succession of closures or cavities. As the screws rotate, the fluid is moved axially from the inlet port to the outlet port in a continuous, uniform flow. This uniform axial flow results in a minimum of fluid pulsation and extremely quiet operation.

The rotating idler rotors generate a hydrodynamic film of fluid which supports the idlers in the housing bores and prohibits wearing contact. The strength of this film is based on fluid viscosity, pump pressure and speed. As pressure requirements increase, the hydrodynamic film can be strengthened by increasing

Applications

Model 3E pumps are designed to meet the requirements for hydraulic, lubricating, seal, distillate, residual and fuel oil applications. These units have been widely utilized in such places as power plants, refineries, fuel oil burners, petrochemical plants, mechanical transmissions, and lubricating seal oil systems—wherever high performance and reliability in a compact design are required.

Typical applications are:

Lubrication of diesel engines, steam turbine/

viscosity or speed. Both the flow rate and pressure capability of the IMO pump increase with speed; thus higher speeds generally result in better performance and longer life.

The symmetrical arrangement of the rotors (screws) eliminates the need for bearings to absorb radial loads. Model 3E pumps contain only one ball bearing which positions the power rotor for proper operation of the mechanical seal. This permanently grease-packed bearing is isolated from the pumpage by the mechanical seal to prevent contamination and improper lubrication.

Model 3E pumps are offered in ten rotor sizes for foot or flange mounted configurations. A variety of construction materials are available to meet operating conditions and job specifications. Complete pump/driver assemblies can be provided as required.

The simple compact design of the Model 3E pump permits fast, easy installation and low maintenance. The bearing and shaft seal are easily replaced when necessary. The pump can be positioned in 90 degree increments to accommodate piping arrangements. Periodic inspection can be made without removing the pump, and routine maintenance can be performed without disturbing system piping.

generator sets, reciprocating and centrifugal compressors, transmission gears, large centrifugal pumps, high inlet pressure refrigeration screw compressors, and other rotating machinery.

Circulation of fuel oils, hydraulic oils, transformer insulating oil and most petroleum based fluids in general.

Transfer, loading and unloading of clean lube, fuel, waste and similar type oils in refineries, factories, storage or settling tanks and lube oil reservoirs.

Model 3E Specifications and Features

CASING	Pearlitic gray iron. Optional cast steel available in all sizes.
ROTOR HOUSING	Pearlitic gray iron. Replaceable in all cast steel models, and in 187 + 200 size cast iron models.
POWER ROTOR	Alloy steel.
IDLER ROTORS	Pearlitic gray iron.
GASKETS	Cellulose and non-asbestos fiber.
PUMP INTERNALS	<p>Type B: (Sizes 87, 87P and 95) Positive drive mechanical seal, Buna-N O-rings and standard external permanently grease packed ball bearing. For all services up to 180°F and/or 25000 SSU.</p> <p>Type B: (Sizes 118-200) Buna-N bellows friction drive mechanical seal, Buna-N O-rings and standard external permanently grease packed ball bearing. Recommended for distillate, lube oil and most lower viscosity, clean oil services in general.</p> <p>Type H: (Sizes 118-200) Positive drive mechanical seal, viton O-rings and external high temperature deep groove ball bearing. Recommended for residual oils and all applications with fluid viscosities above 3000 SSU.</p> <p>Type I: (All sizes) Integral flange mounted pump with sleeve bearing in lieu of a ball bearing and no shaft seal. For applications where pump shaft is within driving machinery enclosure, allowing internal return-to-sump of shaft leakage.</p> <p>Type N: (Available in C.I. case for flange mount—118-200 sizes only) Positive drive balanced mechanical seal, neoprene O-rings, carbon on carbide sealing faces and external grease packed deep groove ball bearing. For applications requiring higher inlet and discharge pressures.</p>
DISCHARGE PRESSURE	<p>150 PSIG maximum (Types B, H and I)</p> <p>350 PSIG maximum (Type N, providing differential pressure does not exceed 150 psi.)</p>
INLET PRESSURE	<p>.25 PSIG maximum (Types B, H and I)</p> <p>300 PSIG maximum (Type N)</p>
VISCOSITY	<p>Type B and I: 33-3000 SSU (2.0-650 CST)</p> <p>Type H: 33-25000 SSU (2.0-5400 CST)</p> <p>Type N: 60-5000 SSU (10-1100 CST)</p>
TEMPERATURE	<p>Type B: 0-180°F</p> <p>Type H, I and N: 0-250°F, assuming fluid is within allowable viscosity limits.</p>
DRIVE	Direct only.
ROTATION	Clockwise facing pump shaft. Optional counterclockwise available on all sizes, except Type N and 187M, 187Y.
MOUNTING	May be foot or flange mounted in any attitude.
CONNECTIONS	All cast iron casing pumps and size 87P, 87 and 95 steel casing pumps are NPT connections. All other steel case pumps are SAE socket weld flanged (provided with pump).
FILTRATION	Inlet strainers are required to keep contaminants and abrasives out of pump, but they must be selected by consultation with strainer vendor to prevent pump starvation. Normally, 60 mesh for light and 1/8"-3/16" openings for heavy oils are recommended.
ACCESSORIES	Pump/motor adapters for NEMA "C" face motors, steel bedplates and completely mounted pump/driver assemblies.

Maximum Operating Speeds (RPM)*

Size	87P, 87, 95	118P	118	143J	143	162	187,187Y,187M	200
Type B, H	5000	4000	4000	4000	4000	4000	4000	3800
Type N	3500	3500	3500	3500	3500	3500	3500	3500
Type I	8000	8000	6500	7000	5500	4800	4250	4000

*Above values assume minimum suction conditions can be met.

Typical 3E Assembly and Mounting Options

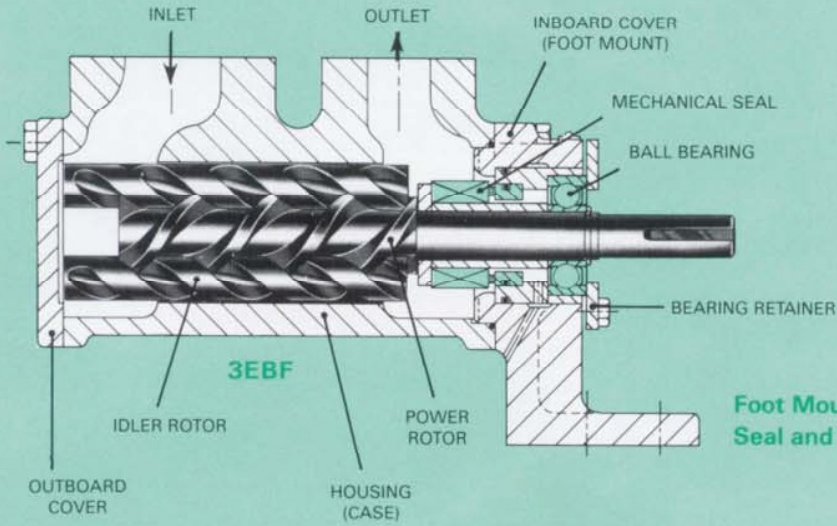

Foot Mount with Mechanical Seal and Ball Bearing

Flange Mount with Mechanical Seal and Ball Bearing

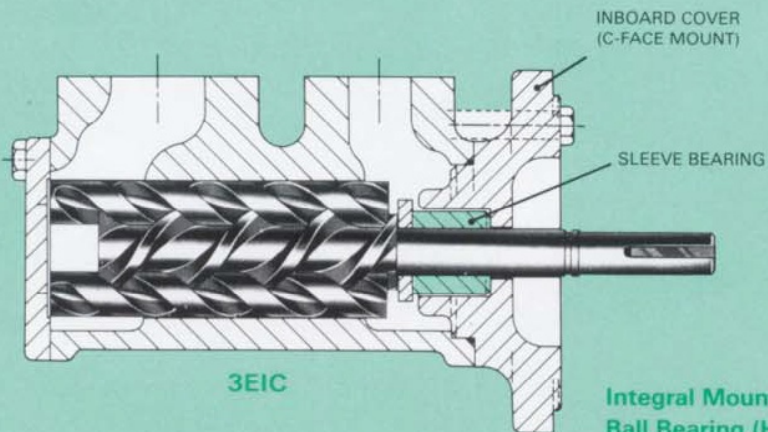
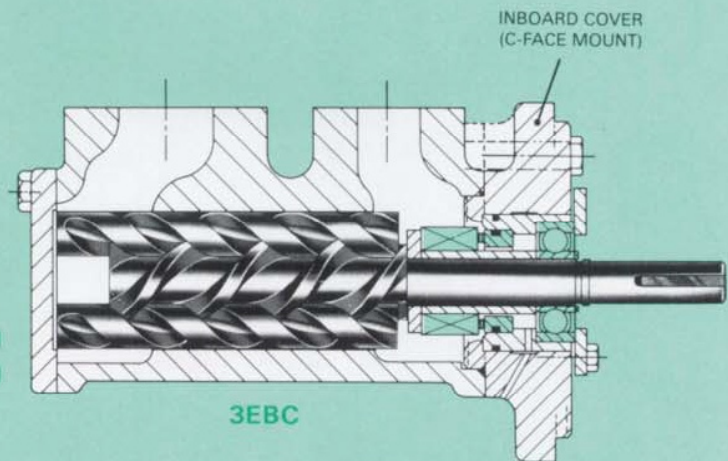

Integral Mount, No Mechanical Seal or Ball Bearing (High Speed)

Model 3E Performance Data

Rotor Size 87P								
Speed 3500 RPM								
Viscosity SSU	Differential Pressure — PSI						Net Inlet Pressure Required (PSIA)	
	25	50	75	100	125	150		
GPM	33	5.8	5.2	4.7	4.3	4.0	3.6	
	65	6.2	5.8	5.4	5.1	4.9	4.7	
	100	6.4	6.0	5.8	5.6	5.4	5.2	
	150	6.6	6.3	6.0	5.9	5.7	5.6	
	650	6.9	6.8	6.7	6.6	6.5	6.4	
	1000	7.0	6.9	6.8	6.7	6.6	6.6	
	5000	7.1	7.1	7.0	7.0	7.0	6.9	
	10000	7.2	7.1	7.1	7.1	7.1	7.0	
BHP	150	0.3	0.4	0.5	0.6	0.7	0.8	4.3
	650	0.6	0.7	0.8	1.0	1.1	1.2	4.4
	1000	0.8	0.9	1.0	1.1	1.2	1.3	4.5
	5000	2.0	2.1	2.2	2.3	2.4	2.5	5.3
	10000	3.0	3.1	3.2	3.3	3.4	3.5	6.1
Speed 1750 RPM								
Viscosity SSU	Differential Pressure — PSI						Net Inlet Pressure Required (PSIA)	
	25	50	75	100	125	150		
GPM	33	2.2	—	—	—	—	—	
	65	2.6	2.1	—	—	—	—	
	100	2.8	2.4	2.2	1.9	—	—	
	150	2.9	2.6	2.4	2.2	2.1	1.9	
	650	3.3	3.2	3.0	3.0	2.9	2.8	
	1000	3.4	3.2	3.2	3.1	3.0	3.0	
	5000	3.5	3.5	3.4	3.4	3.4	3.3	
	10000	3.5	3.5	3.5	3.5	3.4	3.4	
BHP	150	0.1	0.2	0.2	0.3	0.3	0.4	3.7
	650	0.2	0.2	0.3	0.3	0.4	0.5	3.8
	1000	0.2	0.3	0.3	0.4	0.4	0.5	3.9
	5000	0.5	0.6	0.6	0.7	0.7	0.8	4.0
	10000	0.8	0.8	0.9	0.9	1.0	1.0	4.2
Speed 1150 RPM								
Viscosity SSU	Differential Pressure — PSI						Net Inlet Pressure Required (PSIA)	
	25	50	75	100	125	150		
GPM	33	—	—	—	—	—	—	
	65	1.3	—	—	—	—	—	
	100	1.5	—	—	—	—	—	
	150	1.7	1.4	—	—	—	—	
	650	2.0	1.9	1.8	1.7	1.6	1.6	
	1000	2.1	2.0	1.9	1.8	1.8	1.7	
	5000	2.3	2.2	2.2	2.1	2.1	2.1	
	10000	2.3	2.3	2.2	2.2	2.2	2.2	
BHP	150	0.1	0.1	—	—	—	—	3.6
	650	0.1	0.1	0.2	0.2	0.2	0.3	3.6
	1000	0.1	0.1	0.2	0.2	0.3	0.3	3.6
	5000	0.2	0.3	0.3	0.3	0.4	0.4	3.7
	10000	0.4	0.4	0.4	0.5	0.5	0.5	3.8

Rotor Size 87								
Speed 3500 RPM								
Viscosity SSU	Differential Pressure — PSI						Net Inlet Pressure Required (PSIA)	
	25	50	75	100	125	150		
GPM	33	7.6	7.0	6.5	6.1	5.8	5.4	
	65	8.0	7.6	7.2	7.0	6.7	6.5	
	100	8.2	7.9	7.6	7.4	7.2	7.0	
	150	8.4	8.1	7.9	7.7	7.5	7.4	
	650	8.7	8.6	8.5	8.4	8.3	8.2	
	1000	8.8	8.7	8.6	8.5	8.5	8.4	
	5000	8.9	8.9	8.8	8.8	8.8	8.8	
	10000	9.0	8.9	8.9	8.9	8.9	8.8	
BHP	150	0.3	0.5	0.6	0.7	0.9	1.0	4.7
	650	0.7	0.8	0.9	1.1	1.2	1.3	4.9
	1000	0.8	1.0	1.1	1.2	1.4	1.5	5.0
	5000	2.0	2.1	2.3	2.4	2.5	2.7	6.2
	10000	3.0	3.1	3.3	3.4	3.5	3.7	7.9
Speed 1750 RPM								
Viscosity SSU	Differential Pressure — PSI						Net Inlet Pressure Required (PSIA)	
	25	50	75	100	125	150		
GPM	33	3.1	2.4	—	—	—	—	
	65	3.5	3.0	2.7	2.4	—	—	
	100	3.7	3.3	3.1	2.8	2.6	2.5	
	150	3.8	3.6	3.3	3.1	3.0	2.8	
	650	4.2	4.1	4.0	3.9	3.8	3.7	
	1000	4.3	4.1	4.1	4.0	3.9	3.9	
	5000	4.4	4.4	4.3	4.3	4.3	4.2	
	10000	4.4	4.4	4.4	4.4	4.3	4.3	
BHP	150	0.1	0.2	0.3	0.3	0.4	0.5	3.9
	650	0.2	0.3	0.3	0.4	0.5	0.5	4.0
	1000	0.2	0.3	0.4	0.4	0.5	0.6	4.1
	5000	0.5	0.6	0.7	0.7	0.8	0.9	4.4
	10000	0.8	0.9	0.9	1.0	1.1	1.1	4.7
Speed 1150 RPM								
Viscosity SSU	Differential Pressure — PSI						Net Inlet Pressure Required (PSIA)	
	25	50	75	100	125	150		
GPM	33	1.5	—	—	—	—	—	
	65	1.9	1.5	—	—	—	—	
	100	2.1	1.8	1.5	—	—	—	
	150	2.3	2.0	1.8	1.6	—	—	
	650	2.6	2.5	2.4	2.3	2.2	2.2	
	1000	2.7	2.6	2.5	2.4	2.4	2.3	
	5000	2.9	2.8	2.8	2.7	2.7	2.7	
	10000	2.9	2.9	2.8	2.8	2.8	2.8	
BHP	150	0.1	0.1	0.2	0.2	—	—	3.7
	650	0.1	0.1	0.2	0.2	0.3	0.3	3.7
	1000	0.1	0.2	0.2	0.3	0.3	0.3	3.8
	5000	0.3	0.3	0.3	0.4	0.4	0.5	3.9
	10000	0.4	0.4	0.5	0.5	0.5	0.6	4.1

Rotor Size 95								
Speed 3500 RPM								
Viscosity SSU	Differential Pressure — PSI						Net Inlet Pressure Required (PSIA)	
	25	50	75	100	125	150		
GPM	33	9.9	9.1	8.6	8.1	7.7	7.3	
	65	10.3	9.8	9.4	9.1	8.8	8.6	
	100	10.6	10.2	9.9	9.6	9.4	9.1	
	150	10.8	10.4	10.2	10.0	9.8	9.6	
	650	11.2	11.0	10.9	10.8	10.7	10.6	
	1000	11.3	11.1	11.0	11.0	10.9	10.8	
	5000	11.4	11.4	11.3	11.3	11.3	11.2	
	10000	11.5	11.4	11.4	11.4	11.4	11.3	
BHP	150	0.4	0.6	0.8	1.0	1.1	1.3	4.8
	650	0.8	1.0	1.2	1.4	1.5	1.7	5.0
	1000	1.1	1.2	1.4	1.6	1.7	1.9	5.2
	5000	2.6	2.7	2.9	3.1	3.2	3.4	6.8
	10000	3.9	4.0	4.2	4.4	4.5	4.7	8.8
Speed 1750 RPM								
Viscosity SSU	Differential Pressure — PSI						Net Inlet Pressure Required (PSIA)	
	25	50	75	100	125	150		
GPM	33	4.1	3.3	—	—	—	—	
	65	4.6	4.0	3.7	3.3	3.0	—	
	100	4.8	4.4	4.1	3.8	3.6	3.4	
	150	5.0	4.6	4.4	4.2	4.0	3.8	
	650	5.4	5.2	5.1	5.0	4.9	4.8	
	1000	5.5	5.3	5.2	5.2	5.1	5.0	
	5000	5.7	5.6	5.5	5.5	5.5	5.4	
	10000	5.7	5.7	5.6	5.6	5.6	5.5	
BHP	150	0.2	0.2	0.3	0.4	0.5	0.6	4.0
	650	0.3	0.3	0.4	0.5	0.6	0.7	4.1
	1000	0.3	0.4	0.5	0.6	0.6	0.7	4.1
	5000	0.7	0.8	0.9	0.9	1.0	1.1	4.4
	10000	1.0	1.1	1.2	1.3	1.4	1.4	4.8
Speed 1150 RPM								
Viscosity SSU	Differential Pressure — PSI						Net Inlet Pressure Required (PSIA)	
	25	50	75	100	125	150		
GPM	33	2.1	—	—	—	—	—	
	65	2.6	2.1	—	—	—	—	
	100	2.8	2.4	2.1	—	—	—	
	150	3.0	2.7	2.4	2.2	2.0	—	
	650	3.4	3.3	3.1	3.0	2.9	2.8	
	1000	3.5	3.4	3.3	3.2	3.1	3.0	
	5000	3.7	3.6	3.6	3.5	3.5	3.5	
	10000	3.7	3.7	3.6	3.6	3.6	3.6	
BHP	150	0.1	0.1	0.2	0.3	0.3	—	3.7
	650	0.1	0.2	0.2	0.3	0.4	0.4	3.7
	1000	0.2	0.2	0.3	0.3	0.4	0.4	3.8
	5000	0.3	0.4	0.4	0.5	0.5	0.6	3.9
	10000	0.5	0.5	0.6	0.6	0.7	0.7	4.1

Rotor Size 118P								
Speed 3500 RPM								
Viscosity SSU	Differential Pressure — PSI						Net Inlet Pressure Required (PSIA)	
	25	50	75	100	125	150		
GPM	33	15.4	14.3	13.4	12.7	12.0	11.5	
	65	16.2	15.4	14.8	14.2	13.8	13.4	
	100	16.5	15.9	15.4	15.0	14.6	14.3	
	150	16.8	16.3	15.9	15.6	15.3	15.0	
	650	17.5	17.2	17.0	16.9	16.7	16.6	
	1000	17.6	17.4	17.2	17.1	17.0	16.9	
	5000	17.9	17.8	17.7	17.7	17.6	17.6	
	10000	17.9	17.9	17.8	17.8	17.8	17.7	
BHP	150	0.8	1.1	1.3	1.6	1.9	2.1	4.8
	650	1.6	1.9	2.1	2.4	2.6	2.9	5.0
	1000	2.0	2.3	2.5	2.8	3.1	3.3	5.2
	5000	5.0	5.2	5.5	5.7	6.0	6.3	6.8
	10000	7.5	7.7	8.0	8.3	8.5	8.8	8.8
Speed 1750 RPM								
Viscosity SSU	Differential Pressure — PSI						Net Inlet Pressure Required (PSIA)	
	25	50	75	100	125	150		
GPM	33	6.3	5.2	—	—	—	—	
	65	7.1	6.3	5.7	5.2	4.7	—	
	100	7.5	6.8	6.4	5.9	5.6	5.2	
	150	7.8	7.3	6.8	6.5	6.2	5.9	
	650	8.4	8.2	8.0	7.8	7.7	7.6	
	1000	8.6	8.4	8.2	8.1	7.9	7.8	
	5000	8.8	8.7	8.7	8.6	8.6	8.5	
	10000	8.9	8.8	8.8	8.7	8.7	8.7	
BHP	150	0.3	0.4	0.5	0.7	0.8	0.9	4.0
	650	0.5	0.6	0.7	0.9	1.0	1.1	4.1
	1000	0.6	0.7	0.8	1.0	1.1	1.2	4.1
	5000	1.3	1.5	1.6	1.7	1.9	2.0	4.4
	10000	2.0	2.1	2.2	2.4	2.5	2.6	4.8
Speed 1150 RPM								
Viscosity SSU	Differential Pressure — PSI						Net Inlet Pressure Required (PSIA)	
	25	50	75	100	125	150		
GPM	33	3.2	—	—	—	—	—	
	65	4.0	3.2	—	—	—	—	
	100	4.4	3.7	3.3	—	—	—	
	150	4.7	4.2	3.7	3.4	3.1	—	
	650	5.3	5.1	4.9	4.7	4.6	4.5	
	1000	5.5	5.3	5.1	5.0	4.8	4.7	
	5000	5.7	5.6	5.6	5.5	5.5	5.4	
	10000	5.8	5.7	5.7	5.6	5.6	5.6	
BHP	150	0.1	0.2	0.3	0.4	0.5	—	3.7
	650	0.2	0.3	0.4	0.5	0.6	0.7	3.7
	1000	0.3	0.4	0.5	0.5	0.6	0.7	3.8
	5000	0.6	0.7	0.8	0.9	1.0	1.0	3.9
	10000	0.9	1.0	1.1	1.1	1.2	1.3	4.1

1. For conditions between listed values, interpolate between those values. For conditions not listed or off tables, Contact IMO.
2. Net Inlet Pressure Required is minimum pressure above vapor pressure at pump inlet to prevent cavitation. This assumes that the fluid is air and gas free.
3. For BHP values at viscosities below 150 SSU, use values listed for 150 SSU.

Model 3E Performance Data

Rotor Size 118								
Speed 3500 RPM								
Viscosity SSU	Differential Pressure — PSI						Net Inlet Pressure Required (PSIA)	
	25	50	75	100	125	150		
GPM	33	19.9	18.8	17.9	17.2	16.6	16.0	
	65	20.7	19.9	19.3	18.8	18.3	17.9	
	100	21.1	20.4	19.9	19.5	19.1	18.8	
	150	21.4	20.8	20.4	20.1	19.8	19.5	
	650	22.0	21.8	21.6	21.4	21.3	21.1	
	1000	22.1	21.9	21.8	21.6	21.5	21.4	
	5000	22.4	22.3	22.2	22.2	22.1	22.1	
	10000	22.5	22.4	22.4	22.3	22.3	22.2	
BHP	150	0.9	1.2	1.5	1.9	2.2	2.5	5.4
	650	1.7	2.0	2.3	2.6	3.0	3.3	5.8
	1000	2.1	2.4	2.7	3.1	3.4	3.7	6.0
	5000	5.0	5.3	5.7	6.0	6.3	6.7	8.8
	10000	7.5	7.9	8.2	8.5	8.8	9.2	14.7
Speed 1750 RPM								
Viscosity SSU	Differential Pressure — PSI						Net Inlet Pressure Required (PSIA)	
	25	50	75	100	125	150		
GPM	33	8.6	7.5	6.6	5.9	—	—	
	65	9.4	8.6	8.0	7.5	7.0	6.6	
	100	9.8	9.1	8.6	8.2	7.8	7.5	
	150	10.0	9.5	9.1	8.8	8.5	8.2	
	650	10.7	10.4	10.3	10.1	9.9	9.8	
	1000	10.8	10.6	10.5	10.3	10.2	10.1	
	5000	11.1	11.0	10.9	10.9	10.8	10.8	
	10000	11.2	11.1	11.0	11.0	11.0	10.9	
BHP	150	0.3	0.5	0.6	0.8	1.0	1.1	4.1
	650	0.5	0.7	0.8	1.0	1.2	1.3	4.3
	1000	0.6	0.8	0.9	1.1	1.3	1.4	4.3
	5000	1.4	1.5	1.7	1.9	2.0	2.2	4.9
	10000	2.0	2.2	2.3	2.5	2.7	2.8	5.6
Speed 1150 RPM								
Viscosity SSU	Differential Pressure — PSI						Net Inlet Pressure Required (PSIA)	
	25	50	75	100	125	150		
GPM	33	4.7	—	—	—	—	—	
	65	5.5	4.7	4.1	—	—	—	
	100	5.9	5.2	4.7	4.3	4.0	—	
	150	6.2	5.6	5.2	4.9	4.6	4.3	
	650	6.8	6.6	6.4	6.2	6.1	5.9	
	1000	6.9	6.7	6.6	6.4	6.3	6.2	
	5000	7.2	7.1	7.1	7.0	6.9	6.9	
	10000	7.3	7.2	7.2	7.1	7.1	7.1	
BHP	150	0.2	0.3	0.4	0.5	0.6	0.7	3.8
	650	0.3	0.4	0.5	0.6	0.7	0.8	3.8
	1000	0.3	0.4	0.5	0.6	0.7	0.8	3.9
	5000	0.6	0.7	0.8	1.0	1.1	1.2	4.1
	10000	0.9	1.0	1.1	1.2	1.3	1.5	4.3

Rotor Size 143J								
Speed 3500 RPM								
Viscosity SSU	Differential Pressure — PSI						Net Inlet Pressure Required (PSIA)	
	25	50	75	100	125	150		
GPM	33	26.9	25.5	24.5	23.6	22.9	22.2	
	65	27.8	26.8	26.1	25.5	24.9	24.4	
	100	28.2	27.5	26.9	26.4	25.9	25.5	
	150	28.6	27.9	27.5	27.1	26.7	26.4	
	650	29.4	29.1	28.8	28.6	28.5	28.3	
	1000	29.5	29.3	29.1	28.9	28.8	28.7	
	5000	29.8	29.7	29.6	29.6	29.5	29.5	
	10000	29.9	29.8	29.8	29.7	29.7	29.6	
BHP	150	1.4	1.8	2.3	2.7	3.1	3.6	5.2
	650	2.8	3.2	3.7	4.1	4.5	5.0	5.4
	1000	3.5	4.0	4.4	4.8	5.3	5.7	5.7
	5000	8.8	9.2	9.6	10.1	10.5	11.0	7.8
	10000	13.2	13.6	14.1	14.5	15.0	15.4	11.5
Speed 1750 RPM								
Viscosity SSU	Differential Pressure — PSI						Net Inlet Pressure Required (PSIA)	
	25	50	75	100	125	150		
GPM	33	11.8	10.5	9.4	8.6	7.8	—	
	65	12.7	11.8	11.1	10.4	9.9	9.4	
	100	13.2	12.4	11.8	11.3	10.9	10.5	
	150	13.5	12.9	12.4	12.0	11.7	11.3	
	650	14.3	14.0	13.8	13.6	13.4	13.3	
	1000	14.5	14.2	14.0	13.9	13.7	13.6	
	5000	14.8	14.7	14.6	14.5	14.5	14.4	
	10000	14.9	14.8	14.7	14.7	14.6	14.6	
BHP	150	0.5	0.7	0.9	1.1	1.3	1.6	4.0
	650	0.8	1.0	1.3	1.5	1.7	1.9	4.1
	1000	1.0	1.2	1.4	1.7	1.9	2.1	4.2
	5000	2.3	2.6	2.8	3.0	3.2	3.4	4.6
	10000	3.5	3.7	3.9	4.1	4.3	4.6	5.2
Speed 1150 RPM								
Viscosity SSU	Differential Pressure — PSI						Net Inlet Pressure Required (PSIA)	
	25	50	75	100	125	150		
GPM	33	6.6	5.3	—	—	—	—	
	65	7.6	6.6	5.9	5.3	—	—	
	100	8.0	7.3	6.7	6.2	5.7	5.3	
	150	8.4	7.7	7.3	6.9	6.5	6.2	
	650	9.2	8.9	8.6	8.4	8.3	8.1	
	1000	9.3	9.1	8.9	8.7	8.6	8.4	
	5000	9.6	9.5	9.4	9.4	9.3	9.2	
	10000	9.7	9.6	9.6	9.5	9.5	9.4	
BHP	150	0.2	0.4	0.5	0.7	0.8	1.0	3.7
	650	0.4	0.6	0.7	0.8	1.0	1.1	3.8
	1000	0.5	0.6	0.8	0.9	1.1	1.2	3.9
	5000	1.1	1.2	1.4	1.5	1.6	1.8	4.0
	10000	1.6	1.7	1.9	2.0	2.1	2.3	4.2

Rotor Size 143								
Speed 3500 RPM								
Viscosity SSU	Differential Pressure — PSI						Net Inlet Pressure Required (PSIA)	
	25	50	75	100	125	150		
GPM	33	36.2	34.5	33.3	32.2	31.3	30.4	
	65	37.3	36.1	35.2	34.5	33.8	33.2	
	100	37.9	36.9	36.2	35.6	35.0	34.5	
	150	38.3	37.5	36.9	36.4	36.0	35.6	
	650	39.2	38.9	38.6	38.3	38.1	37.9	
	1000	39.4	39.1	38.9	38.7	38.5	38.4	
	5000	39.8	39.7	39.6	39.5	39.4	39.3	
BHP	150	1.5	2.1	2.7	3.3	3.9	4.5	6.2
	650	2.9	3.5	4.1	4.7	5.3	5.9	6.8
	1000	3.7	4.2	4.8	5.4	6.0	6.6	7.2
	5000	8.9	9.5	10.1	10.7	11.2	11.8	13.7
Speed 1750 RPM								
Viscosity SSU	Differential Pressure — PSI						Net Inlet Pressure Required (PSIA)	
	25	50	75	100	125	150		
GPM	33	16.1	14.5	13.2	12.1	11.2	10.3	
	65	17.2	16.1	15.2	14.4	13.7	13.1	
	100	17.8	16.8	16.1	15.5	15.0	14.5	
	150	18.2	17.4	16.8	16.3	15.9	15.5	
	650	19.2	18.8	18.5	18.3	18.1	17.9	
	1000	19.3	19.0	18.8	18.6	18.5	18.3	
	5000	19.7	19.6	19.5	19.4	19.3	19.3	
	10000	19.8	19.7	19.7	19.6	19.6	19.5	
BHP	150	0.5	0.8	1.1	1.4	1.7	2.0	4.3
	650	0.9	1.2	1.5	1.8	2.1	2.4	4.4
	1000	1.1	1.4	1.7	2.0	2.2	2.5	4.5
	5000	2.4	2.7	3.0	3.3	3.6	3.9	5.3
	10000	3.5	3.8	4.1	4.4	4.7	5.0	6.1
Speed 1150 RPM								
Viscosity SSU	Differential Pressure — PSI						Net Inlet Pressure Required (PSIA)	
	25	50	75	100	125	150		
GPM	33	9.2	7.6	—	—	—	—	
	65	10.4	9.2	8.3	7.5	6.9	—	
	100	10.9	10.0	9.2	8.6	8.1	7.6	
	150	11.3	10.6	10.0	9.5	9.0	8.6	
	650	12.3	11.9	11.6	11.4	11.2	11.0	
	1000	12.5	12.2	11.9	11.7	11.6	11.4	
	5000	12.9	12.7	12.6	12.5	12.5	12.4	
	10000	13.0	12.9	12.8	12.7	12.7	12.6	
BHP	150	0.3	0.5	0.7	0.9	1.1	1.3	4.0
	650	0.5	0.6	0.8	1.0	1.2	1.4	4.1
	1000	0.5	0.7	0.9	1.1	1.3	1.5	4.1
	5000	1.1	1.3	1.5	1.7	1.9	2.1	4.4
	10000	1.6	1.8	2.0	2.2	2.4	2.6	4.8

Rotor Size 162								
Speed 3500 RPM								
Viscosity SSU	Differential Pressure — PSI						Net Inlet Pressure Required (PSIA)	
	25	50	75	100	125	150		
GPM	33	52.9	50.8	49.2	47.8	46.6	45.6	
	65	54.4	52.9	51.7	50.7	49.9	49.1	
	100	55.1	53.9	52.9	52.1	51.5	50.8	
	150	55.6	54.6	53.9	53.2	52.7	52.1	
	650	56.8	56.4	56.0	55.7	55.4	55.2	
	1000	57.1	56.7	56.4	56.1	55.9	55.7	
	5000	57.6	57.4	57.3	57.1	57.1	57.0	
BHP	150	2.2	3.1	3.9	4.8	5.6	6.4	7.0
	650	4.2	5.1	5.9	6.8	7.6	8.5	7.9
	1000	5.3	6.1	7.0	7.8	8.7	9.5	8.6
	2000	7.7	8.5	9.4	10.2	11.1	11.9	10.9
	5000	12.9	13.7	14.6	15.4	16.2	17.1	25.0
Speed 1750 RPM								
Viscosity SSU	Differential Pressure — PSI						Net Inlet Pressure Required (PSIA)	
	25	50	75	100	125	150		
GPM	33	23.9	21.8	20.2	18.8	17.6	16.6	
	65	25.4	23.9	22.7	21.8	20.9	20.1	
	100	26.1	24.9	23.9	23.2	22.5	21.9	
	150	26.6	25.6	24.9	24.2	23.7	23.2	
	650	27.8	27.4	27.0	26.7	26.4	26.2	
	1000	28.1	27.7	27.4	27.1	26.9	26.7	
	5000	28.6	28.4	28.3	28.2	28.1	28.0	
	10000	28.7	28.6	28.5	28.4	28.3	28.3	
BHP	150	0.8	1.2	1.6	2.0	2.5	2.9	4.4
	650	1.3	1.7	2.1	2.6	3.0	3.4	4.6
	1000	1.6	2.0	2.4	2.8	3.2	3.7	4.7
	5000	3.5	3.9	4.3	4.7	5.2	5.6	5.7
	10000	5.1	5.5	6.0	6.4	6.8	7.2	6.9
Speed 1150 RPM								
Viscosity SSU	Differential Pressure — PSI						Net Inlet Pressure Required (PSIA)	
	25	50	75	100	125	150		
GPM	33	14.0	11.9	10.3	—	—	—	
	65	15.4	13.9	12.8	11.8	11.0	10.2	
	100	16.1	14.9	14.0	13.2	12.5	11.9	
	150	16.7	15.7	14.9	14.3	13.7	13.2	
	650	17.9	17.4	17.1	16.8	16.5	16.2	
	1000	18.1	17.7	17.5	17.2	17.0	16.8	
	5000	18.6	18.5	18.3	18.2	18.1	18.0	
	10000	18.8	18.6	18.5	18.5	18.4	18.3	
BHP	150	0.4	0.7	1.0	1.3	1.5	1.8	4.0
	650	0.7	0.9	1.2	1.5	1.8	2.0	4.1
	1000	0.8	1.0	1.3	1.6	1.9	2.2	4.2
	5000	1.6	1.9	2.2	2.4	2.7	3.0	4.6
	10000	2.3	2.6	2.9	3.2	3.4	3.7	5.2

1. For conditions between listed values, interpolate between those values. For conditions not listed or off tables, Contact IMO.
2. Net Inlet Pressure Required is minimum pressure above vapor pressure at pump inlet to prevent cavitation. This assumes that the fluid is air and gas free.
3. For BHP values at viscosities below 150 SSU, use values listed for 150 SSU.

Model 3E Performance Data

Rotor Size 187								
Speed 3500 RPM								
Viscosity SSU	Differential Pressure — PSI						Net Inlet Pressure Required (PSIA)	
	25	50	75	100	125	150		
GPM	33	82.3	79.5	77.4	75.6	74.0	72.5	
	65	84.2	82.3	80.7	79.4	78.3	77.3	
	100	85.2	83.6	82.3	81.3	80.4	79.6	
	150	85.9	84.6	83.6	82.7	82.0	81.3	
	650	87.5	86.9	86.4	86.0	85.7	85.3	
	1000	87.8	87.3	86.9	86.6	86.3	86.1	
	2500	88.3	88.0	87.7	87.5	87.3	87.1	
BHP	150	3.4	4.7	6.0	7.3	8.6	9.9	8.5
	650	6.5	7.8	9.1	10.4	11.7	13.0	10.5
	1000	8.1	9.4	10.7	12.0	13.3	14.6	11.8
	1500	10.1	8.7	12.7	14.0	15.3	16.6	14.2
	2500	13.3	14.6	15.9	17.2	18.5	19.8	21.0
Speed 1750 RPM								
Viscosity SSU	Differential Pressure — PSI						Net Inlet Pressure Required (PSIA)	
	25	50	75	100	125	150		
GPM	33	37.8	35.0	32.8	31.0	29.4	28.0	
	65	39.7	37.7	36.2	34.9	33.8	32.7	
	100	40.6	39.0	37.8	36.8	35.9	35.0	
	150	41.4	40.0	39.0	38.2	37.4	36.8	
	650	43.0	42.4	41.9	41.5	41.1	40.8	
	1000	43.3	42.8	42.4	42.1	41.8	41.5	
	5000	44.0	43.8	43.6	43.4	43.3	43.2	
	10000	44.1	44.0	43.9	43.8	43.7	43.6	
	BHP	150	1.2	1.8	2.5	3.1	3.8	
650		2.0	2.6	3.3	3.9	4.6	5.2	5.0
1000		2.4	3.0	3.7	4.3	5.0	5.6	5.2
5000		5.3	6.0	6.6	7.3	7.9	8.6	6.8
10000		7.9	8.5	9.2	9.8	10.5	11.1	8.8
Speed 1150 RPM								
Viscosity SSU	Differential Pressure — PSI						Net Inlet Pressure Required (PSIA)	
	25	50	75	100	125	150		
GPM	33	22.5	19.7	17.6	15.8	—	—	
	65	24.5	22.5	20.9	19.6	18.5	17.5	
	100	25.4	23.8	22.5	21.5	20.6	19.8	
	150	26.1	24.8	23.8	22.9	22.2	21.5	
	650	27.7	27.1	26.6	26.2	25.9	25.5	
	1000	28.0	27.5	27.1	26.8	26.5	26.3	
	5000	28.7	28.5	28.3	28.2	28.0	27.9	
	10000	28.9	28.7	28.6	28.5	28.4	28.3	
	BHP	150	0.7	1.1	1.5	1.9	2.4	
650		1.0	1.4	1.9	2.3	2.7	3.1	4.3
1000		1.2	1.6	2.0	2.5	2.9	3.3	4.3
5000		2.5	2.9	3.3	3.8	4.2	4.6	4.9
10000		3.6	4.0	4.4	4.9	5.3	5.7	5.6

Rotor Size 200								
Speed 3500 RPM								
Viscosity SSU	Differential Pressure — PSI						Net Inlet Pressure Required (PSIA)	
	25	50	75	100	125	150		
GPM	33	100.4	97.2	94.8	92.7	90.9	89.3	
	65	102.6	100.3	98.6	97.1	95.8	94.7	
	100	103.7	101.8	100.4	99.3	98.2	97.3	
	150	104.5	103.0	101.8	100.9	100.0	99.3	
	650	106.3	105.6	105.1	104.6	104.2	103.8	
	1000	106.7	106.1	105.7	105.3	105.0	104.7	
	1500	106.9	106.5	106.1	105.8	105.5	105.3	
BHP	150	4.1	5.7	7.3	8.9	10.4	12.0	9.7
	650	7.9	9.5	11.1	12.6	14.2	15.8	12.1
	1000	9.9	11.4	13.0	14.6	16.2	17.7	14.0
	1500	12.2	13.8	15.4	17.0	18.5	20.1	18.0
Speed 1750 RPM								
Viscosity SSU	Differential Pressure — PSI						Net Inlet Pressure Required (PSIA)	
	25	50	75	100	125	150		
GPM	33	46.4	43.2	40.7	38.7	36.9	35.2	
	65	48.6	46.3	44.6	43.1	41.8	40.6	
	100	49.6	47.8	46.4	45.2	44.2	43.2	
	150	50.4	48.9	47.8	46.8	46.0	45.2	
	650	52.3	51.6	51.0	50.6	50.2	49.8	
	1000	52.6	52.1	51.6	51.2	50.9	50.6	
	5000	53.4	53.2	53.0	52.8	52.6	52.5	
	10000	53.6	53.4	53.3	53.2	53.1	53.0	
	BHP	150	1.4	2.2	3.0	3.8	4.6	
650		2.4	3.2	4.0	4.8	5.6	6.3	5.2
1000		2.9	3.7	4.5	5.3	6.0	6.8	5.3
5000		6.5	7.3	8.1	8.9	9.6	10.4	7.1
10000		9.5	10.3	11.1	11.9	12.7	13.5	9.6
Speed 1150 RPM								
Viscosity SSU	Differential Pressure — PSI						Net Inlet Pressure Required (PSIA)	
	25	50	75	100	125	150		
GPM	33	27.8	24.6	22.2	20.2	18.3	—	
	65	30.0	27.8	26.0	24.6	23.3	22.1	
	100	31.1	29.3	27.9	26.7	25.6	24.7	
	150	31.9	30.4	29.3	28.3	27.5	26.7	
	650	33.8	33.1	32.5	32.1	31.6	31.3	
	1000	34.1	33.5	33.1	32.7	32.4	32.1	
	5000	34.9	34.6	34.4	34.3	34.1	34.0	
	10000	35.1	34.9	34.7	34.6	34.5	34.4	
	BHP	150	0.8	1.3	1.8	2.4	2.9	
650		1.2	1.7	2.3	2.8	3.3	3.8	4.4
1000		1.4	2.0	2.5	3.0	3.5	4.0	4.5
5000		3.0	3.5	4.0	4.6	5.1	5.6	5.2
10000		4.3	4.9	5.4	5.9	6.4	6.9	5.9

1. For conditions between listed values, interpolate between those values. For conditions not listed or off tables, Contact IMO.
2. Net Inlet Pressure Required is minimum pressure above vapor pressure at pump inlet to prevent cavitation. This assumes that the fluid is air and gas free.
3. For BHP values at viscosities below 150 SSU, use values listed for 150 SSU.

Model 3E Dimensions

Rotor Sizes 87P, 87 & 95

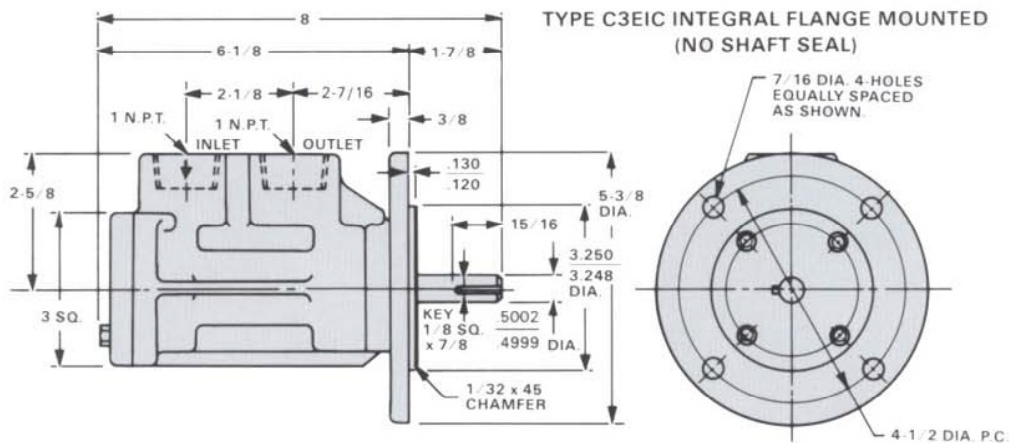
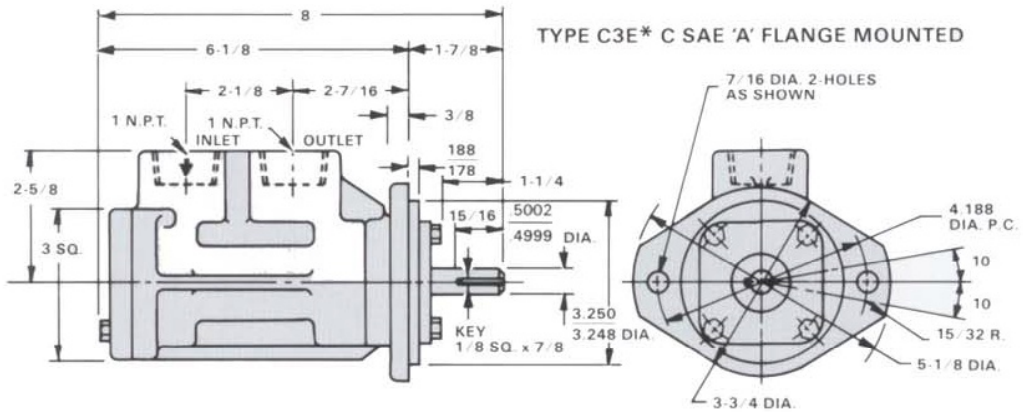
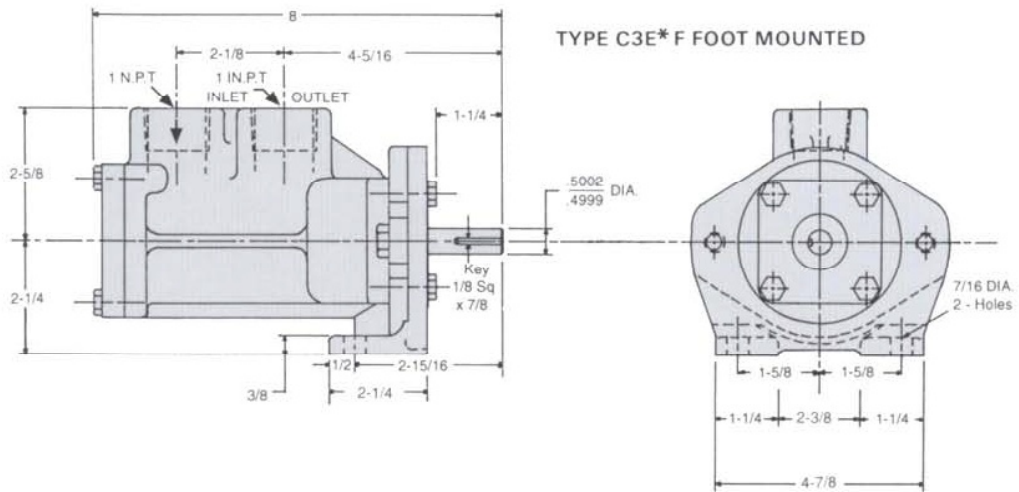

All dimensions to the nearest 1/16 inch - not to scale. Weight - 9 lbs.

OFFICE	ROTATION <input type="checkbox"/> CW <input type="checkbox"/> CCW(D)	CASE MATERIAL <input type="checkbox"/> IRON <input type="checkbox"/> STEEL	CERTIFIED BY	DATE
CUSTOMER			CUSTOMER ORDER	
MODEL NO			IMO ORDER	

Model 3E Dimensions

Rotor Sizes 118P & 118

TYPE C3E * F FOOT MOUNTED

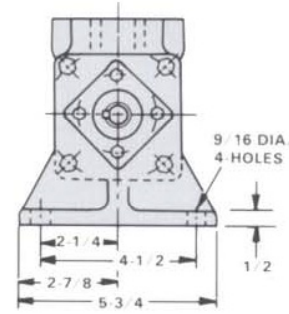

*IRON CASED PUMPS HAVE NPT PORTS AS SHOWN
 *STEEL CASED PUMPS HAVE SAE FLANGE PADS FOR USE WITH SAE 4 BOLT SOCKET WELD FLANGES (PROVIDED WITH PUMP) SEE PAGE 12 FOR DIMENSIONS.

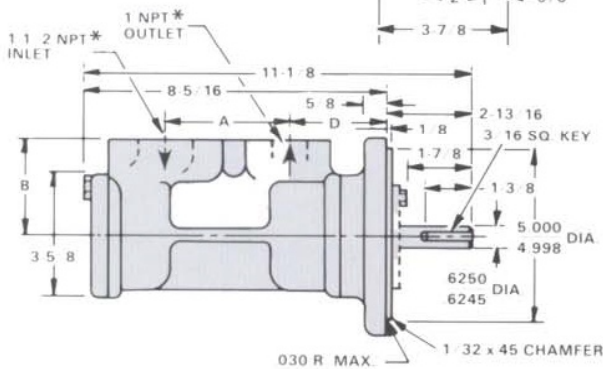
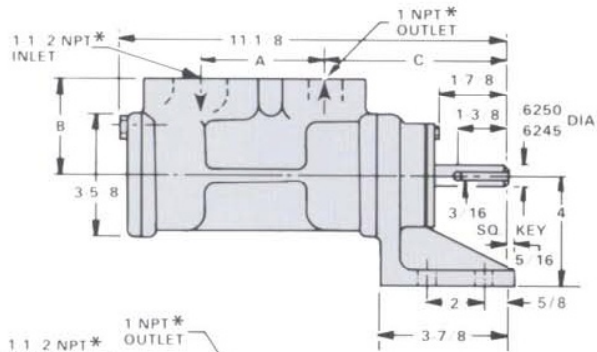

TYPES C3E * "C" FLANGE MOUNTED

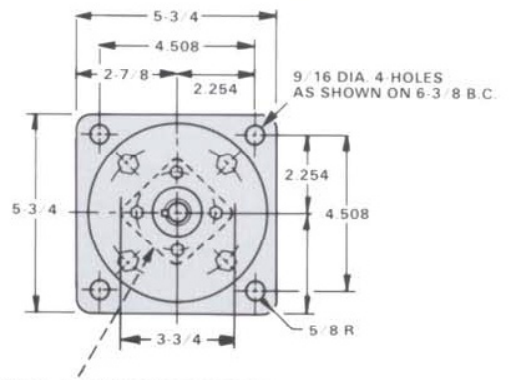

2-7/8" SQ. x 1/4" THICK W/ 3/8" RADIUS CORNERS. FOR MECHANICAL SEAL MODEL (3E * C) ONLY NOT PRESENT ON INTEGRAL FLANGE MOUNT (3EIC) MODELS.

C3EIC- INTEGRAL FLANGE MOUNT-NO SEAL

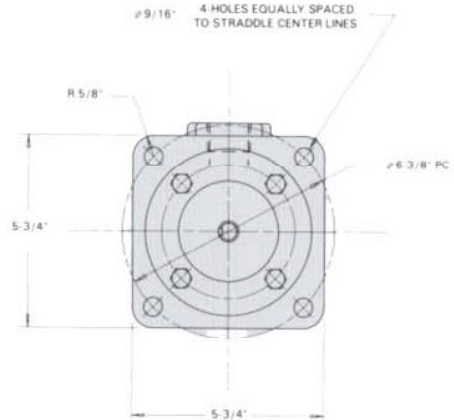
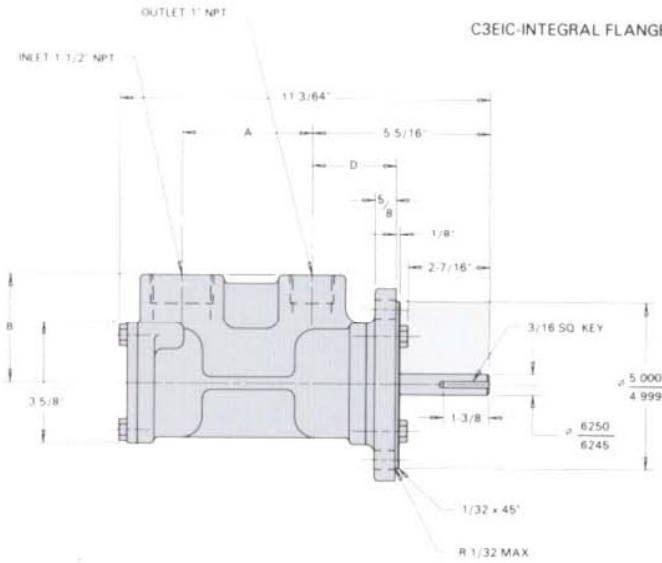

CASE MATERIAL	A	B	C	D
IRON	3-7/8	3-1/4	5-3/8	2-1/2
STEEL	3-1/2	2-3/4	5-1/4	2-3/8

All dimensions to the nearest 1/16 inch - not to scale. Weight - 27 lbs.

OFFICE	ROTATION <input type="checkbox"/> CW <input type="checkbox"/> CCW(D)	CASE MATERIAL <input type="checkbox"/> IRON <input type="checkbox"/> STEEL	CERTIFIED BY	DATE
CUSTOMER			CUSTOMER ORDER	
MODEL NO			IMO ORDER	

Model 3E Dimensions

Rotor Sizes 143J, 143 & 162

TYPE 3E * F FOOT MOUNTED

*IRON CASED PUMPS HAVE NPT PORTS AS SHOWN.

*STEEL CASED PUMPS HAVE SAE FLANGE PADS FOR USE WITH SAE 4 BOLT SOCKET WELD FLANGES (PROVIDED WITH PUMP) SEE PAGE 12 FOR DIMENSIONS.

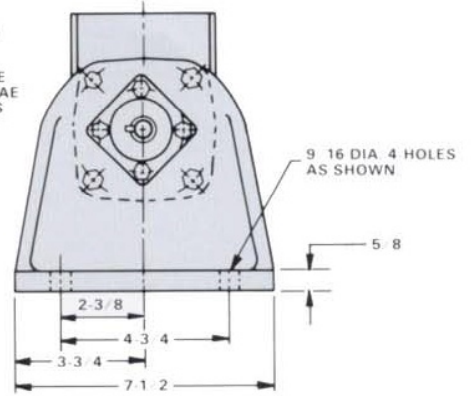
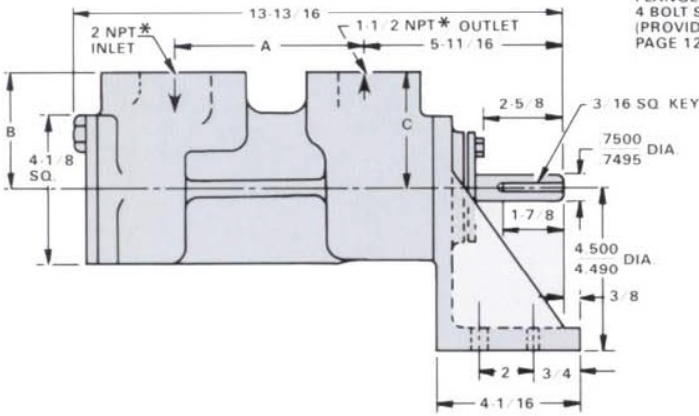

TYPES 3E * C FLANGE MOUNTED

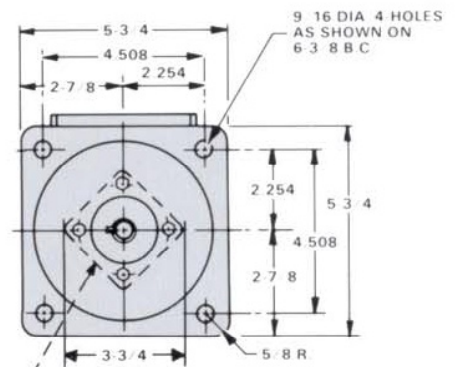
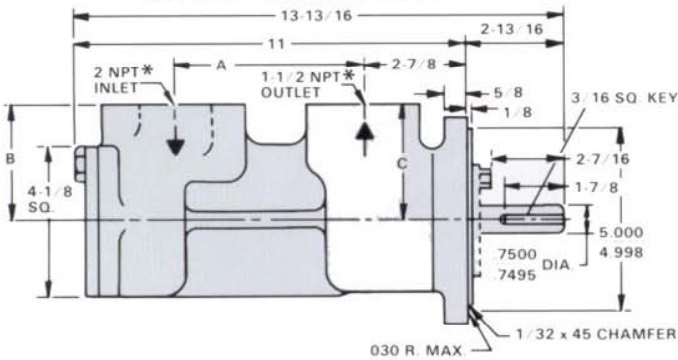

2.7/8" SQ. BY 1/4" THICK W/ 3/8" RADIUS CORNERS FOR MECHANICAL SEAL MODEL (3E * C ***) ONLY. NOT PRESENT ON INTEGRAL FLANGE MOUNT

C3E1C-INTEGRAL FLANGE MOUNT-NO SEAL

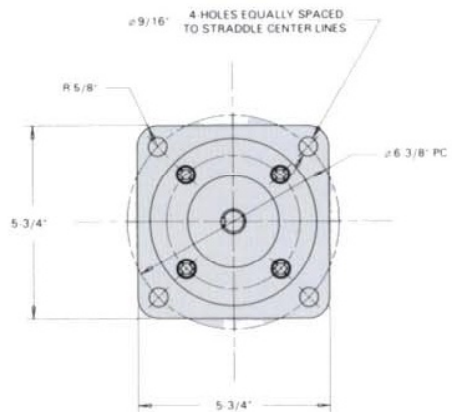
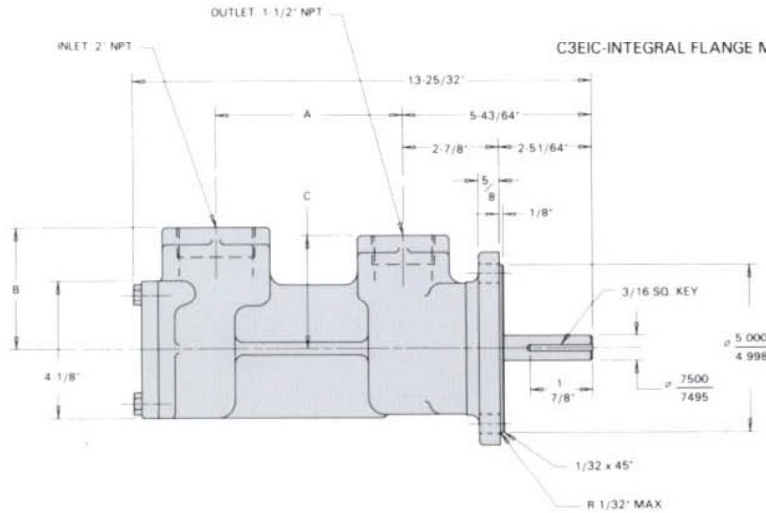

CASE MATERIAL	A	B	C
IRON	5-5/8	3-5/8	3-3/8
STEEL	5-1/4	3-1/4	3-1/4

All dimensions to the nearest 1/16 inch - not to scale. Weight - 38 lbs.

OFFICE	ROTATION <input type="checkbox"/> CW <input type="checkbox"/> CCW(D)	CASE MATERIAL <input type="checkbox"/> IRON <input type="checkbox"/> STEEL	CERTIFIED BY	DATE
CUSTOMER			CUSTOMER ORDER	
MODEL NO			IMO ORDER	

Model 3E Dimensions

Rotor Sizes 187 & 200

*Iron Case Pumps have NPT ports.
2-1/2" Inlet - 2" Outlet.

*Steel Case Pumps have SAE flange pads for use with SAE 4-bolt socket-weld flanges which are provided with the pump.
3" Inlet - 2" Outlet. See dimensions below.

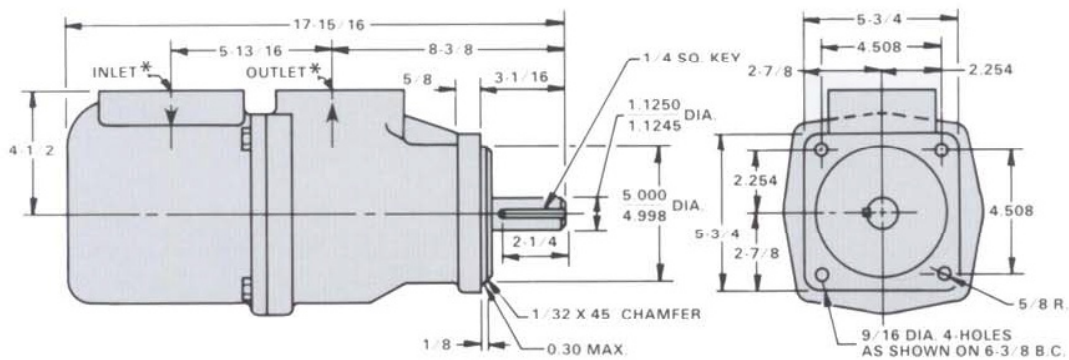
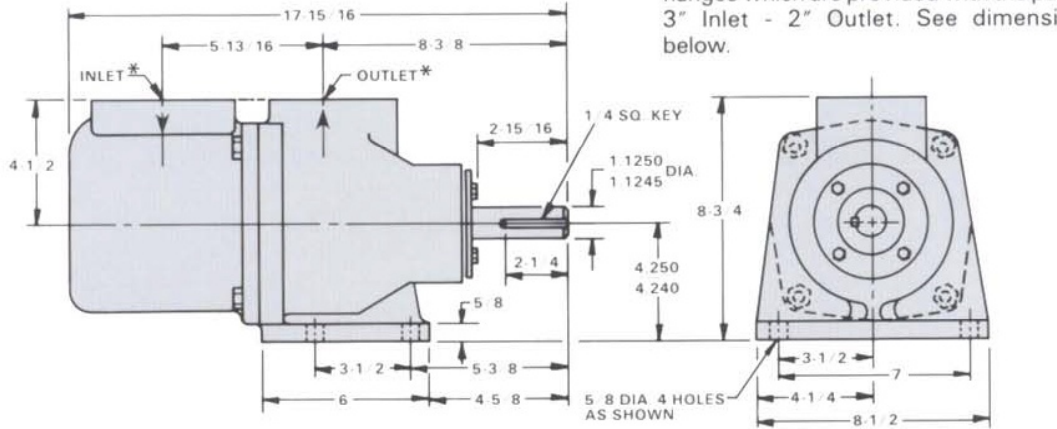

SAE 4-bolt socket-weld flanges (for steel case pumps 118 thru 200 sizes)

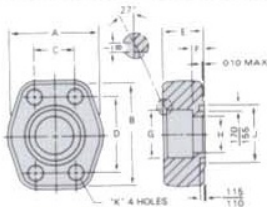

Part Number	Pipe Size	Pad Size	A	B	C	D	E	F	G Dia.	H Dia.	J Dia.	K Dia.
W4-16-16	1.00	1.00	2.31	2.75	1.031	2.062	.88	.25	1.328	1.00	1.560	.406
W4-24-24	1.50	1.50	3.25	3.69	1.406	2.750	1.19	.44	1.922	1.50	2.120	.531
W4-32-32	2.00	2.00	3.81	4.00	1.688	3.062	1.38	.50	2.406	2.00	2.495	.531
W4-48-48	3.00	3.00	5.16	5.31	2.438	4.188	2.12	.88	3.547	3.00	3.620	.656

All dimensions to the nearest 1/16 inch - not to scale. Weight - 92 lbs.

OFFICE	ROTATION <input type="checkbox"/> CW <input type="checkbox"/> CCW(D)	CASE MATERIAL <input type="checkbox"/> IRON <input type="checkbox"/> STEEL	CERTIFIED BY	DATE
CUSTOMER			CUSTOMER ORDER	
MODEL NO			IMO ORDER	

Series 3E PUMP TO 'C' FACE MOTOR BRACKETS

BRACKET NO. S5333DH (MAXIMUM COUPLING O.D. = 3") WEIGHT 12 LBS. MATES WITH MOTOR FRAMES 56C, 143TC, 145TC.

FOR USE WITH PUMP 3E-87P, 87, 95 WITH SAE BOLT FLANGE MOUNTING

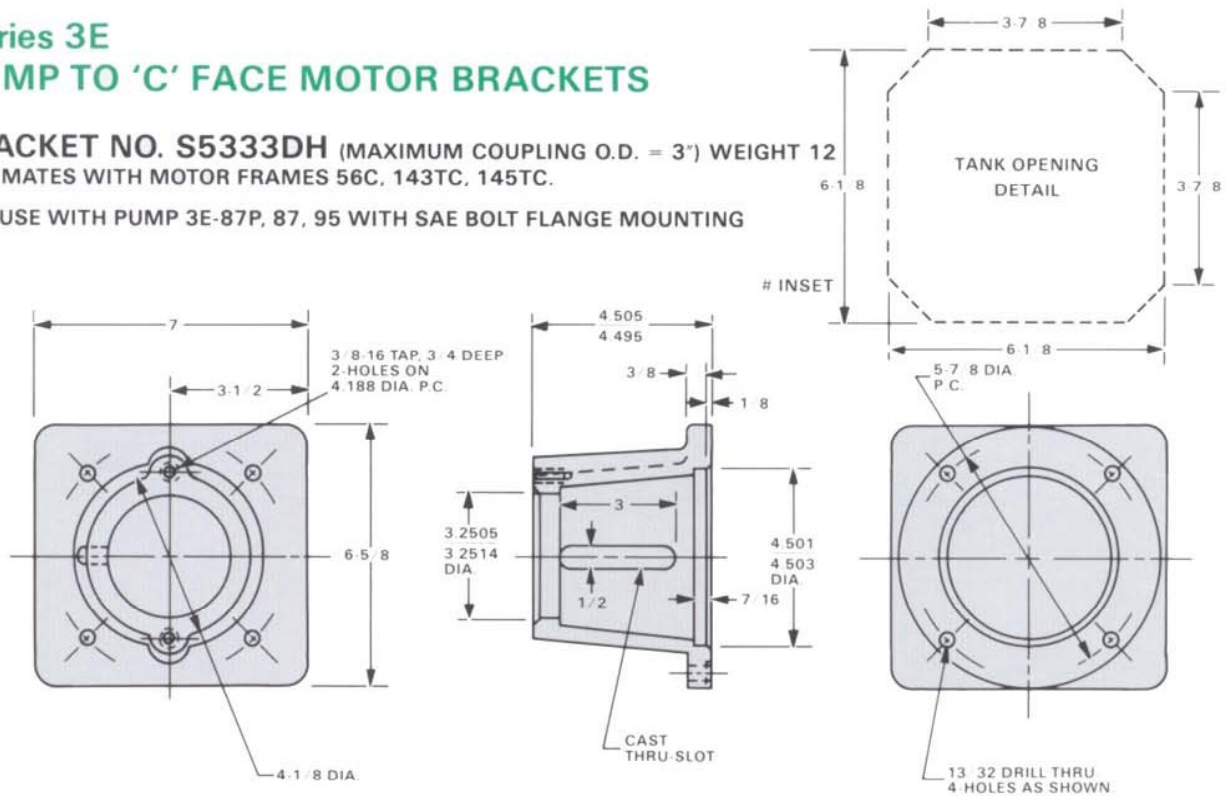

This bracket is suitable for vertical tank mount arrangement.
Drill 4 corner holes 7/16 dia. similar to brackets below. See inset of tank cover hole size.

FOR USE WITH PUMP 3E-118P, 118, 143J, 143, 162, 187, 200 WITH SAE 4 BOLT FLANGE MOUNTING

MOTOR FRAMES	PUMP ROTOR SIZES	BRACKET	WHERE USED		A	B	B ¹	C	D	E	F	G	H	J, Δ	Lbs.
			HORIZONTAL	TANK TOP											
56C-145C	118 to 200	S5333DL	—	X	6-3/16	B	—	4.501	5-7/8	7/16	4	11-1/4	3-1/2	8-1/4	23
	118 to 200	S5333DLX1	X	—	6-3/16	B	7-15/16	4.501	5-7/8	7/16	4	—	3-1/2	—	22
182TC-184TC	118 to 162	S5333DP	X	—	6	8-7/8**	—	8.501	7-1/4	9/16	4	—	3-7/8	—	19
182TC-256TC	118 to 200	S5333DJ	—	X	7-7/16	B	—	8.501	7-1/4	9/16	4	11-1/4	4	8-3/8	22
213TC-256TC	187 to 200		X	—	7-7/16	B	—	8.501	7-1/4	9/16	4	11-1/4	4	—	22
284TSC-369TSC	118 to 200	S5333DK	X	X	7-5/16	14	—	12.501	11	11/16	8	16	4	12	37

*284TSC and 286TSC motors must have large (12-1/2") 'AK' diam
**Supplied with a Round Flange

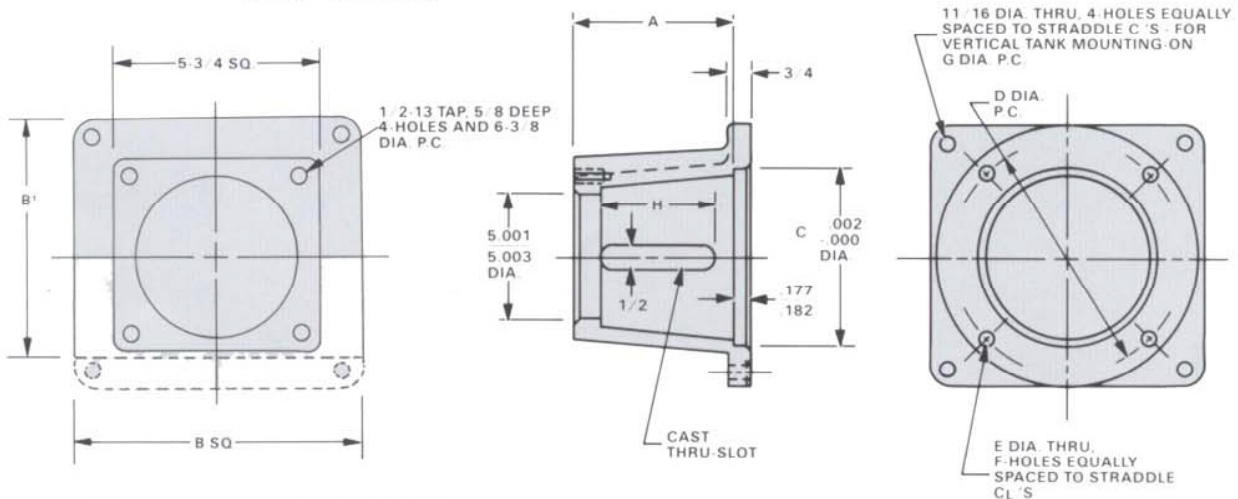

Δ All brackets except S5333DLX1 and S5333DP, are suitable for vertical tank mount arrangement. Hole diameter in tank cover to mount bracket should be "J".

MATERIAL: ASTM A48, CL.40B CAST IRON, DIMENSIONS IN INCHES NOT TO SCALE.

MAXIMUM COUPLING O.D. 4-3/4". SELECT FLEXIBLE COUPLING TO ACCOMMODATE: MAXIMUM COUPLING O.D., MOTOR TORQUE, SHAFT TO SHAFT GAP AND PUMP AND MOTOR SHAFT DIAMETERS.

Typical 3E Pump/Motor Arrangements

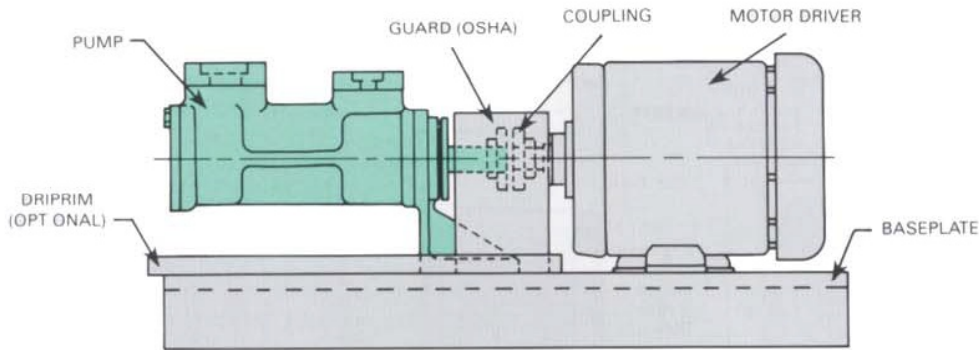

HORIZONTAL FOOT MOUNTED

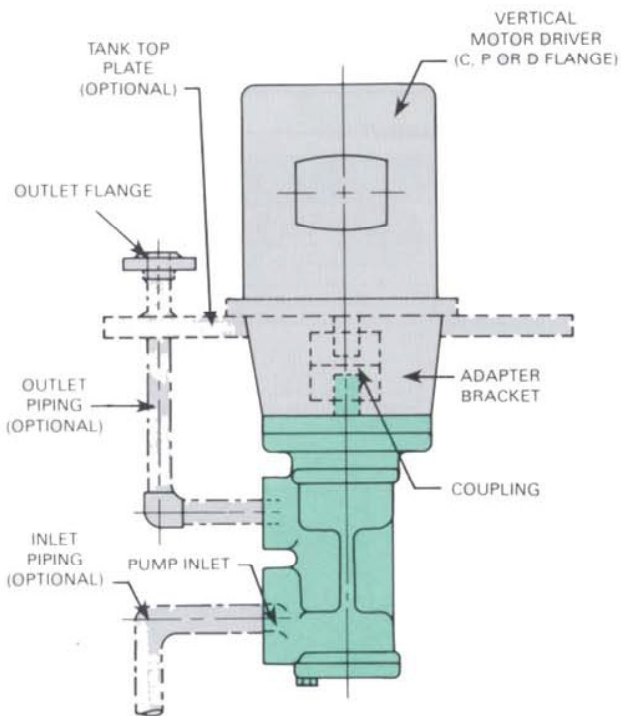

VERTICALLY IN-TANK MOUNTED WITH OPTIONAL DISCHARGE PIPING AND TANKPLATE

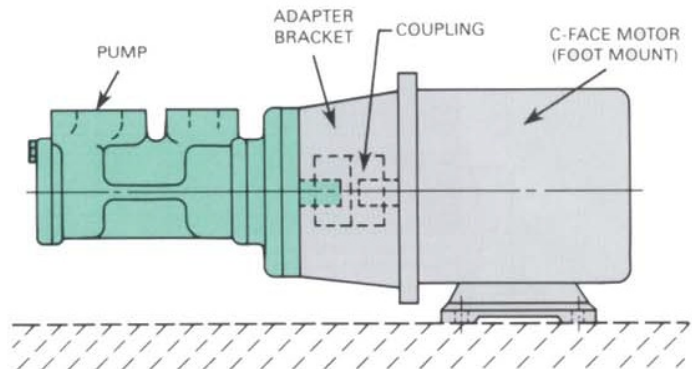

FLANGED PUMP, MOUNTED TO C-FACE MOTOR WITH BRACKET

NOTES:

1. Pump/motor assemblies with OSHA type coupling guard and shaft coupling, factory mounted on a steel baseplate (with or without driprim) are available upon request.
2. Factory mounted pump/motor assemblies, complete with bracket, shaft coupling plus optional mounting plate, inlet (suction) and outlet (discharge) piping are available upon request.
3. For arrangements or variations not shown, consult IMO.

Effect of Temperature on Hydraulic Oil Viscosity

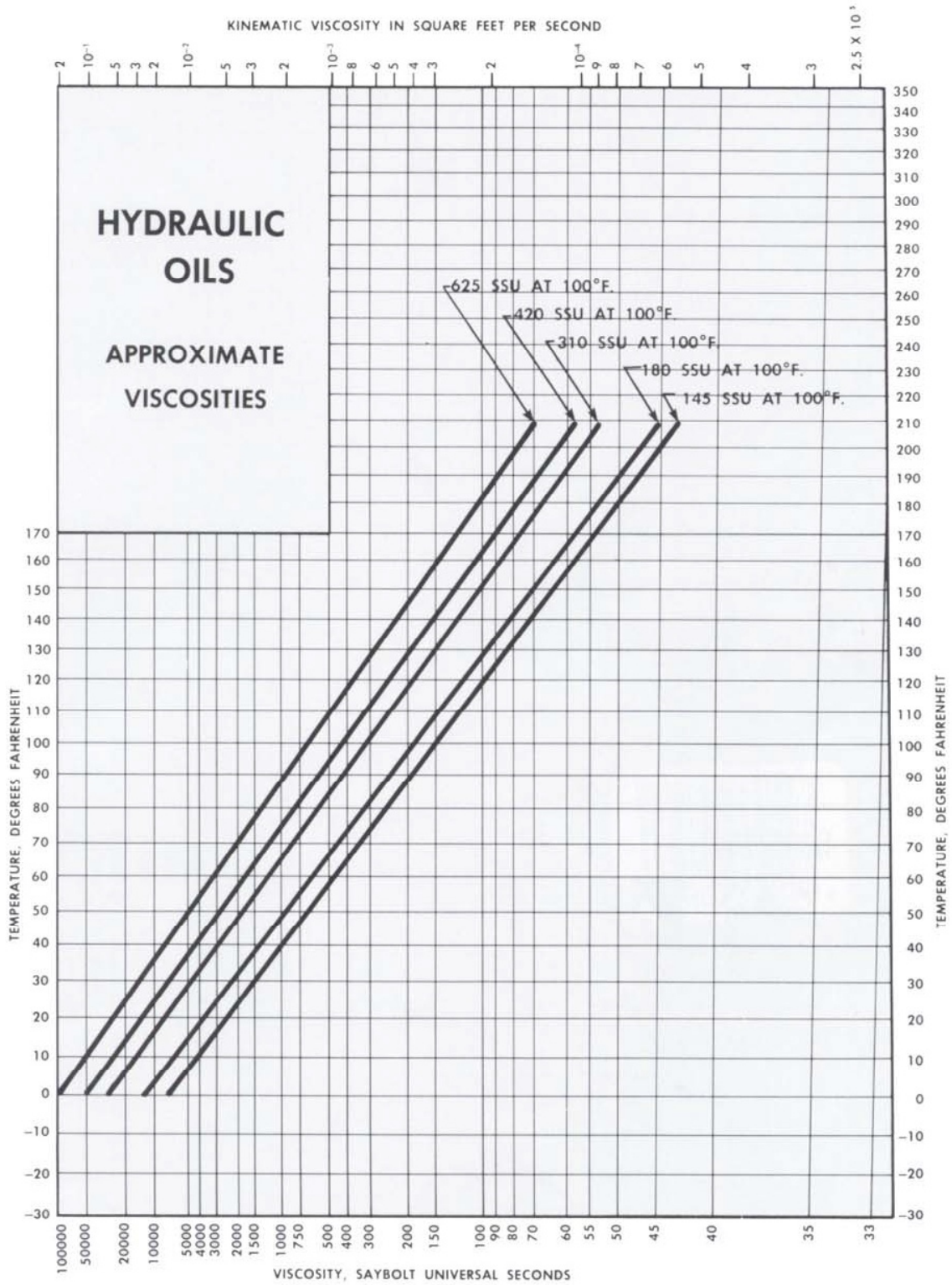

Typical 3E Nomenclature

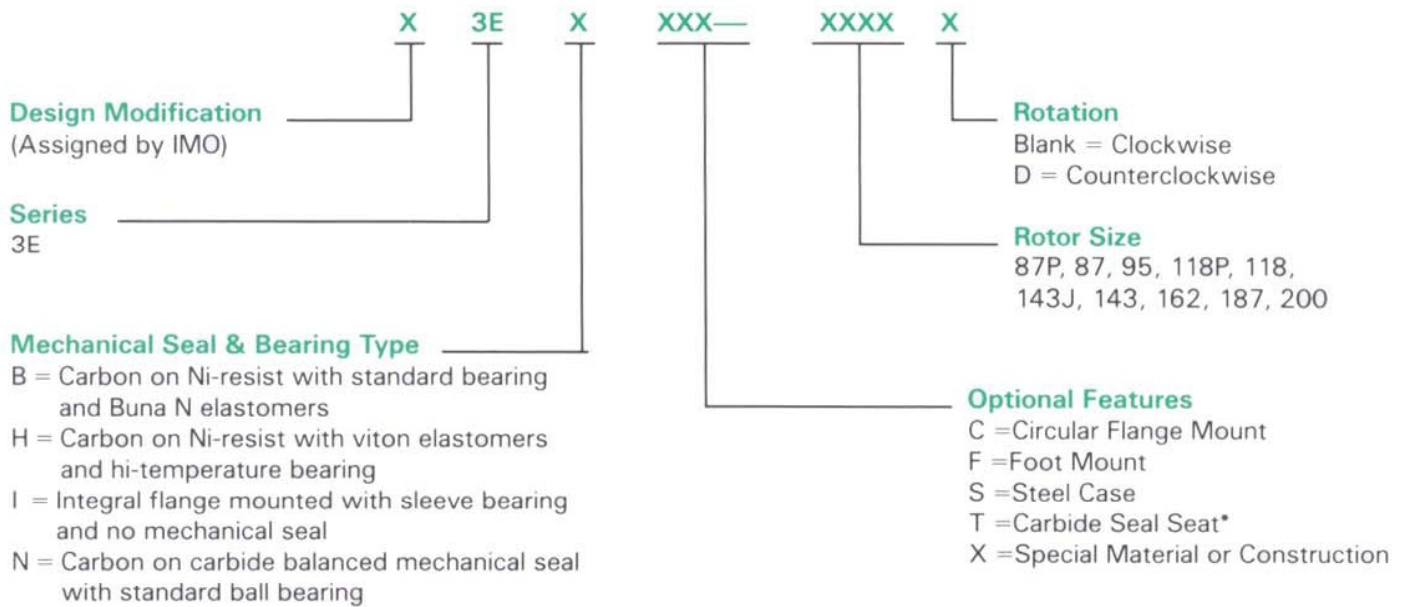

Examples:

C3EBC-187
C3EHFS-143

Model 3E with standard seal and bearing, flange mounted, cast iron casing with 187 rotor size.
Model 3E with positive drive mechanical seal (standard faces), high temperature bearing, foot mounted, steel casing with 143 rotor size.

*Consult IMO for optional mechanical seal materials.



Quality Management System



© 2000 Imo Pump All rights reserved.

BROCHURE: BR00003E REV: 00 5-9-2006



A Member of the
COLFAX PUMP GROUP

Imo Pump

1710 Airport Road
PO Box 5020
Monroe, NC
28111.5020
USA

tel +1 (704) 289 6511
fax +1 (704) 289 9273

E-mail
Imo.Pump@ColfaxCorp.com
Internet
<http://www.imo-pump.com>